

Definitions of finiteness based on order properties

by

Omar De la Cruz (West Lafayette, IN, and Barcelona),
Damir D. Dzhafarov (West Lafayette, IN) and
Eric J. Hall (Kansas City, MO)

Abstract. A *definition of finiteness* is a set-theoretical property of a set that, if the Axiom of Choice (AC) is assumed, is equivalent to stating that the set is finite; several such definitions have been studied over the years. In this article we introduce a framework for generating definitions of finiteness in a systematical way: basic definitions are obtained from properties of certain classes of binary relations, and further definitions are obtained from the basic ones by closing them under subsets or under quotients.

We work in set theory without AC to establish relations of implication and independence between these definitions, as well as between them and other notions of finiteness previously studied in the literature. It turns out that several well known definitions of finiteness (including Dedekind finiteness) fit into our framework by being equivalent to one of our definitions; however, a few of our definitions are actually new. We also show that I_a -finite unions of I_a -finite sets are P -finite (one of our new definitions), but that the class of P -finite sets is not provably closed under unions.

1. Introduction. It is well known that several characterizations of finiteness fail to be equivalent if the Axiom of Choice (AC) is not assumed. The standard definition, namely, that a set is finite if it has n elements for some natural number n , is absolute for transitive models of Zermelo–Fraenkel (ZF) set theory (we also call this *I-finiteness*, cf. Section 2, Definition 1). On the other hand, notions like Dedekind finiteness (a set is Dedekind finite if it is not equinumerous with any proper subset) are equivalent to the standard definition in every model of ZFC (ZF plus AC), but are satisfied by some infinite sets in some models of ZF.

2000 *Mathematics Subject Classification*: 03E25, 03E20, 03E35, 06A07.

Key words and phrases: axiom of choice, finiteness, partial orders.

Research of D. Dzhafarov and E. Hall partially supported by NSF VIGRE grant no. DMS-9983601.

The authors wish to thank Thomas Jech and Jean Rubin for helpful suggestions.

One of the reasons that led some researchers to introduce different definitions of finiteness was a foundational concern: how to capture the concept of finiteness without making use of external objects like the natural numbers (see Tarski [at24]). That concern soon became irrelevant, as a canonical way of representing natural numbers as sets was devised; nevertheless, the definitions of finiteness remain a useful way of classifying non-well-orderable sets according to their cardinal-invariant properties.

In this paper we introduce a framework for generating definitions of finiteness systematically. We start from the following observation, which holds under AC: A set X is finite if and only if

(1.1) *any transitive, antisymmetric binary relation on X has a maximal element.*

We modify (1.1) to obtain four definitions of finiteness by considering the following four classes of binary relations: partial orders, linear orders, tree orders, and well-orders. Notice that all these relations are transitive and antisymmetric (dropping any of these two conditions makes the notion of maximal elements useless in this context); also, reflexivity and irreflexivity are included whenever needed, since they are irrelevant for the existence of maximal elements. See Definition 4 for the actual statements (property (1.1) corresponds to P-finiteness).

In the last section we will look at certain “finite unions of finite sets,” where *finite* can mean one of the less restrictive notions of finiteness mentioned above and detailed in Section 2. Note that with AC, any finite union of finite sets is finite, and so it is natural to ask which notions of finiteness are closed under “finite” unions in set theory without AC. In ZF, it is easy to verify that I-finiteness is closed under unions of I-finite families of sets, and that Dedekind finiteness is closed under unions of Dedekind-finite families, but at the same time it is known that several well studied definitions do not have this property. In this paper we will show that Ia-finite unions of Ia-finite sets (cf. Section 2, Definition 1) are P-finite (cf. Section 2, Definition 4); however, we also show that P-finiteness is not provably (in ZF) closed under P-finite unions.

2. Definitions. In order to establish the relative strength of the notions of finiteness we will introduce in this paper, we dedicate the first part of this section to listing some of those notions of finiteness that have already been studied in the literature in some detail. These will comprise Definitions 1, 2, and 3 below, which were collected in Howard and Rubin [hr98] and De la Cruz [odlc02].

DEFINITION 1. A set X is:

- (1) *I-finite* if every non-empty family of subsets of X has a maximal (or minimal) element under inclusion.
- (2) *Ia-finite* if it is not the disjoint union of two non-I-finite sets.
- (3) *II-finite* if every family of subsets of X linearly ordered by inclusion contains a maximal element.
- (4) *III-finite* if there is no one-to-one map from $\mathcal{P}(X)$ into a proper subset of $\mathcal{P}(X)$.
- (5) *IV-finite* if there is no one-to-one map from X into a proper subset of X .
- (6) *V-finite* if $X = \emptyset$ or there is no one-to-one map from $2 \times X$ into X .
- (7) *VI-finite* if X is empty or a singleton, or else there is no one-to-one map from $X \times X$ into X .
- (8) *VII-finite* if X is I-finite or it is not well-orderable.

Definitions Ia and VII are due to Lévy, while definition IV is due to Dedekind [rd72]. Tarski [at24] introduced I, II, III and V; definition VI was attributed to Tarski by Mostowski [am38].

REMARK 1.

- (1) Tarski [at24] observed, without using AC, that a set is I-finite if and only if it is finite in the ordinary sense mentioned in the introduction (i.e., having n elements with $n \in \omega$). Thus, the terms finite and I-finite may be used interchangeably, though we shall prefer to use the former here.
- (2) In ZF, a set is IV-infinite if and only if it contains a well-orderable infinite subset, and III-infinite if and only if it has a well-orderable infinite partition.

The next group of definitions is due to Truss [jt74].

DEFINITION 2. Define the following classes of cardinals:

- (1) $\Delta_1 = \{\mathfrak{a} : \mathfrak{a} = \mathfrak{b} + \mathfrak{c} \rightarrow \mathfrak{b} \text{ or } \mathfrak{c} \text{ is finite}\}$,
- (2) $\Delta_2 = \{|X| : \text{any linearly ordered partition of } X \text{ is finite}\}$,
- (3) $\Delta_3 = \{|X| : \text{any linearly ordered subset of } X \text{ is finite}\}$,
- (4) $\Delta_4 = \{\mathfrak{a} : \text{there does not exist a function from } \mathfrak{a} \text{ onto } \aleph_0\}$,
- (5) $\Delta_5 = \{\mathfrak{a} : \text{there does not exist a function from } \mathfrak{a} \text{ onto } \mathfrak{a} + 1\}$.

For $i = 1, \dots, 5$, we will say that a set X is Δ_i -finite if $|X| \in \Delta_i$.

REMARK 2. It is clear that Ia-finiteness is equivalent to Δ_1 -finiteness. Truss notes further that II-finiteness is equivalent to Δ_2 -finiteness and III-finiteness to Δ_4 -finiteness.

Lastly, we have the following definition of Howard and Yorke [hy89]:

DEFINITION 3. A set X is *D-finite* if it is empty, a singleton, or if $X = X_1 \cup X_2$, where $|X_1|, |X_2| < |X|$ (such a set is also called *decomposable*).

We now introduce definitions of finiteness derived from classes of order relations, as described in the introduction. It will follow from the implications proved in the next section that these are *bona fide* definitions of finiteness (that is, that they are equivalent to ordinary finiteness under AC).

DEFINITION 4. A set X is:

- (1) *P-finite* if it contains a maximal element under every partial ordering.
- (2) *L-finite* if it contains a maximal element under every linear ordering.
- (3) *W-finite* if it contains a maximal element under every well-ordering.
- (4) *Tr-finite* if it contains a maximal element under every tree ordering.

(A *tree ordering* is a partial ordering in which the set of predecessors of any element forms a well-ordering.)

Next, we introduce a means of deriving new definitions of finiteness from old ones. Let \mathcal{Q} stand for any of the notions given in this section.

DEFINITION 5. A set X is

- (1) \mathcal{Q}^1 -finite if every set that X maps onto is \mathcal{Q} -finite.
- (2) \mathcal{Q}^2 -finite if every set that maps one-to-one into X is \mathcal{Q} -finite.

Our interest in this definition will be the cases where \mathcal{Q} represents one of the notions of finiteness in Definition 4.

REMARK 3.

- (1) It is easy to see that if \mathcal{Q} is any notion of finiteness, then a set X is \mathcal{Q}^1 -finite if and only if every partition of X is \mathcal{Q} -finite, and \mathcal{Q}^2 -finite if and only if every subset of X is \mathcal{Q} -finite.
- (2) The notions of finiteness in Definitions 1, 2, and 3 above are cardinal invariants (cf. De la Cruz [odlc02]). This also holds for the notions in Definition 4, and those obtained from Definition 4 via Definition 5, as can be easily checked case by case.
- (3) Note that each of the notions given in this section yields a corresponding definition of infinity: if \mathcal{Q} is any definition of finiteness, then we will say that a set is \mathcal{Q} -infinite if it is not \mathcal{Q} -finite. In the case of a I-infinite set, we will simply use the equivalent term *infinite*, whereas a Ia-infinite set will be called *partible*. An infinite, Ia-finite set is called *amorphous*.

3. Implications between notions. For the sake of convenience, we will adopt the notation used by De la Cruz [odlc02]. If \mathcal{Q} and \mathcal{Q}' are any notions of finiteness such that whenever a set is \mathcal{Q} -finite then it is \mathcal{Q}' -finite, we will write $\mathcal{Q} \rightarrow \mathcal{Q}'$. We will write $\mathcal{Q} \leftrightarrow \mathcal{Q}'$ if $\mathcal{Q} \rightarrow \mathcal{Q}'$ and $\mathcal{Q}' \rightarrow \mathcal{Q}$.

Lévy [al58] established the following:

$$I \rightarrow I_a \rightarrow II \rightarrow III \rightarrow IV \rightarrow V \rightarrow VI \rightarrow VII,$$

while Truss [jt74] showed that $III \rightarrow \Delta_5 \rightarrow IV$ and $II \rightarrow \Delta_3 \rightarrow IV$. Howard and Yorke [hy89] additionally showed that $IV \rightarrow D \rightarrow VII$.

We begin with some lemmas which we will use to prove the main results of this section.

LEMMA 1. *If \mathcal{Q} is any of the notions of finiteness from Section 2, then $\mathcal{Q}^1 \rightarrow \mathcal{Q}^2 \rightarrow \mathcal{Q}$.*

Proof. The proof will consist mainly of reminding the reader of the definitions.

($\mathcal{Q}^1 \rightarrow \mathcal{Q}^2$) Given a set X , observe that every set that maps one-to-one into X can be mapped onto by X . So if every set that can be mapped onto by X is \mathcal{Q} -finite (i.e. X is \mathcal{Q}^1 -finite), then every set that maps one-to-one into X is \mathcal{Q} -finite (i.e. X is \mathcal{Q}^2 -finite).

($\mathcal{Q}^2 \rightarrow \mathcal{Q}$) Now let X be \mathcal{Q}^2 -finite. This means that every set that maps one-to-one into X , including X itself, is \mathcal{Q} -finite. ■

It is easy to check now that the notions \mathcal{Q}^2 and $(\mathcal{Q}^2)^2$ are equivalent, as are the notions \mathcal{Q}^1 , $(\mathcal{Q}^1)^1$, $(\mathcal{Q}^1)^2$, and $(\mathcal{Q}^2)^1$, meaning that Definition 5 yields at most two new notions of finiteness for each notion \mathcal{Q} .

The task for the remainder of this section will be to find all relations of implication between each of the new notions P, L, Tr, and W, as well as their Definition 5 variants, and the old notions from Definitions 1–3. Several of the old notions will be shown equivalent to new ones, so that what we have are new characterizations of old notions of finiteness in terms of order relations. Other notions from Definition 4 really are new. The implications proved in this section will be the strongest possible in ZF between these notions; the independence results in the next section will show that no stronger implications are provable in ZF.

REMARK 4. Several implications between the new notions are clear. We immediately have $P \rightarrow L \rightarrow W$ and $P \rightarrow Tr \rightarrow W$ (since every linear order is a partial order, and so on). More implications follow from Lemma 1 above, and from the fact that whenever \mathcal{Q} and \mathcal{R} are two notions with $\mathcal{Q} \rightarrow \mathcal{R}$, we have $\mathcal{Q}^1 \rightarrow \mathcal{R}^1$ and $\mathcal{Q}^2 \rightarrow \mathcal{R}^2$.

We now study each of the four notions P, L, Tr, and W one by one together with their Definition 5 variants, beginning with P-finiteness.

THEOREM 1. $P^1 \leftrightarrow P^2 \leftrightarrow P$.

Proof. In view of Lemma 1, it suffices to show that $P \rightarrow P^1$. Take X to be a P-finite set, and suppose $\langle S, \leq \rangle$ is any partial order such that X maps onto S . Say $f : X \rightarrow S$ is a surjection. We define a relation \preceq on X

by the rule that, for all $x, y \in X$, $x \preceq y$ if and only if either $x = y$ or else $f(x) \neq f(y)$ and $f(x) \leq f(y)$. It is easy to see that \preceq partially orders X , and consequently that there is an $x \in X$ which is maximal in X under \preceq . Now suppose there exists an $s \in S$ such that $f(x) \leq s$, meaning there must be a $y \in X$ such that $f(y) = s$ and $x \preceq y$. But this only happens if $x = y$, so $s = f(x)$, and $f(x)$ is in fact maximal in S under \leq . Therefore, we see that S is P-finite and, as a result, that X is P^1 -finite. ■

The next theorem shows that P-finiteness is equivalent to a modification of P-finiteness that may look stronger at first glance. Given a partial order \preceq on a set X , a \preceq -chain is a subset of X that is linearly ordered by \preceq . It is easy to see that X being P-finite is equivalent to X having no infinite chains for any partial order \preceq . It is less obvious that for each \preceq on X , the size of the \preceq -chains must be bounded.

THEOREM 2. *A set X is P-finite if and only if for each partial order \preceq on X , there is a positive integer M such that every \preceq -chain of X has length less than M .*

Proof. Let X be a P-finite set and fix a partial order \preceq on X . For $x \in X$, let $f(x)$ be the maximum integer n such that there is a chain of length n with x at the bottom, if such a maximum exists. For example, if x is a maximal element, then $f(x) = 1$. First, observe that the range of f must be a finite subset of ω (since X is P^1 -finite). Let M be the maximum of the range of f . It just remains to show that $f(x)$ is defined for all $x \in X$; it follows that X has no \preceq -chain of length greater than M .

Let Y be the subset of X on which f is undefined, and suppose by way of contradiction that Y is non-empty. Since X is P^2 -finite, Y is P-finite and must have a \preceq -maximal element y . Since $f(y)$ is undefined, there must be a chain $C \subset X$ starting with y and having length at least $M + 2$. Let x be the second element in the chain, so that $C \setminus \{y\}$ is a chain starting with x of length at least $M + 1$. But now we have a contradiction because $C \setminus \{y\}$ has no elements in Y (since y is maximal in Y), and so $f(x)$ must be defined and at most M . ■

The “moreover” part of the next theorem will be used in Section 5.

THEOREM 3. *Ia \rightarrow P \rightarrow II. Moreover, any P-infinite set has a partition into two P-infinite sets.*

Proof. To see that $P \rightarrow II$ is straightforward, since this implication may be rewritten as $P^1 \rightarrow L^1$ (Theorems 1 and 5), and $P^1 \rightarrow L^1$ follows from $P \rightarrow L$.

Now let X be any P-infinite set. To prove $Ia \rightarrow P$ we just need to show that X has a partition into two infinite parts. It is barely any more work to

show that X has a partition into two P-infinite parts, and that is what we will do.

There exists a partial ordering \preceq on X under which X contains no maximal element. For each $x \in X$ define $B_x = \{y \in X : y \preceq x\}$. In case there is an $x \in X$ such that B_x is P-infinite, we are done since the complement of B_x in X clearly has no \preceq -maximal element so is also P-infinite.

So suppose B_x is P-finite for each $x \in X$. In this case we can define a rank function on X . Let $r(x)$ be the maximum length of any \preceq -chain in B_x . Theorem 2 shows that this r is defined for each $x \in X$. Since X has no \preceq -maximal element, the range $\text{Ran}(r)$ of this rank function must be an unbounded subset of ω . Partition $\text{Ran}(r)$ into two infinite parts. Then the inverse image of each part is a subset of X that r maps onto an infinite well orderable set, so must be P-infinite (in fact III-infinite). ■

Next we study L-finiteness. It should not be surprising that Δ_2 - and Δ_3 -finiteness have characterizations in terms of L-finiteness, since their original definitions are in terms of linear orderings.

LEMMA 2. *If X is infinite and $\langle X, \preceq \rangle$ is a linear order, there exists $Y \subset X$ such that either $\langle Y, \preceq \rangle$ or $\langle Y, \succeq \rangle$ (where $\succeq = \{(a, b) : (b, a) \in \preceq\}$) has no maximum element.*

Proof (by contrapositive). Assume that both (1) every subset of X has a \preceq -maximum and (2) every subset of X has a \preceq -minimum (or, equivalently, a \succeq -maximum). By (2), X is well-ordered by \preceq , say in type α . Now any ordinal of type $\geq \omega$ has an infinite subset with no maximal element (e.g., the set ω). So by (1), we know that $\alpha < \omega$, and consequently X is finite. ■

LEMMA 3. *A set X is L-finite if and only if it is finite or else not linearly orderable.*

Proof. If X is finite or has no linear ordering, then X clearly satisfies the definition of L-finiteness. Conversely, suppose X is infinite and has a linear ordering \leq . By Lemma 2, there is a subset $Y \subseteq X$ with no \leq -maximum (or minimum, but in that case simply reverse the order of \leq). Now it is easy to form a new linear order \preceq on X by modifying \leq so that the two orders agree on Y and on $X \setminus Y$, but in which all elements of $X \setminus Y$ precede all elements of Y under \preceq . This shows X to be L-infinite, since it has no \preceq -maximum. ■

THEOREM 4. $\Delta_3 \leftrightarrow L^2$.

Proof. A set X is L^2 -finite if and only if every subset of X is L-finite (Remark 3(1)). This is equivalent (by Lemma 3) to the condition that every linearly orderable subset of X is finite; i.e., X is Δ_3 -finite. ■

THEOREM 5. $\text{II} \leftrightarrow L^1$.

Proof. A set X is II-finite only if it is Δ_2 -finite (see Remark 2), which means that every linearly ordered partition of X is finite. The proof of this theorem now proceeds just as the proof of Theorem 4, but referring to partitions of X instead of subsets of X . ■

In contrast to L^1 and L^2 , L-finiteness itself is not equivalent to any of our other notions of finiteness. The strongest implications provable in ZF are just the obvious ones in the following statement.

THEOREM 6. $\Delta_3 \rightarrow L \rightarrow VII$.

Proof. Straightforward; rewrite as $L^2 \rightarrow L \rightarrow W$ (by Theorems 4 and 7). ■

The following equivalences involving W-finiteness are closely analogous to equivalences above involving L-finiteness.

THEOREM 7. $VII \leftrightarrow W$.

Proof. Analogously to the proof of Lemma 3, the proof of $VII \rightarrow W$ is trivial. Conversely, suppose X is not VII-finite, so it is both infinite and well-orderable. In that case, the cardinality of X is some \aleph , say \aleph_α . But then X has a well-ordering whose type is the initial ordinal \aleph_α (or ω_α if you prefer that notation). Since \aleph_α has no maximal element, X is not W-finite. ■

THEOREM 8. $IV \leftrightarrow W^2$.

Proof. A set X is W^2 -finite if and only if every subset of X is W-finite (Remark 3(1)). This is equivalent (by Theorem 7) to the condition that every well-orderable subset of X is finite; i.e., X is IV-finite. ■

THEOREM 9. $W^1 \leftrightarrow III$.

Proof. It is probably simplest to replace W by VII and III by Δ_4 and observe that VII^1 (“Every set that X maps onto is finite or non-well-orderable”) is equivalent to Δ_4 (“ X does not map onto \aleph_0 ”). ■

REMARK 5. Several of the notions of finiteness in this paper fall between W^1 and W (i.e. between III and VII), as can be seen in Figure 1 at the end of this section. For any such notion Q with $W^1 \rightarrow Q \rightarrow W$, we have $Q^1 \leftrightarrow W^1 \leftrightarrow III$. (Recall $(W^1)^1 \leftrightarrow W^1$ and Remark 4.)

Finally, we study Tr-finiteness.

THEOREM 10. $\Delta_5 \leftrightarrow Tr^2$.

Proof. ($\Delta_5 \rightarrow Tr^2$) Let X be Tr^2 -infinite, so that there is a subset S of X with a tree ordering \preceq that has no maximal element. Fix some $u \notin X$, and let g be the function that is the identity on $X \setminus S$ and defined on S by

$$g(s) = \begin{cases} \text{the } \preceq \text{-predecessor of } s & \text{if such a predecessor exists,} \\ u & \text{if } s \text{ has no } \preceq \text{-predecessor.} \end{cases}$$

Then g is a surjection from X onto $X \cup \{u\}$, proving that X is Δ_5 -infinite.

($\text{Tr}^2 \rightarrow \Delta_5$) Suppose now that X is Δ_5 -infinite, that is, that there is a function f from X onto $X \cup \{u\}$, with $u \notin X$. We define a tree ordering \preceq of height ω without maximal elements on a subset of X by recursion: take $T_0 = f^{-1}(u)$ (the elements here are the “roots” of the tree); if levels T_0, \dots, T_n have been defined, as well as \preceq on $T_0 \cup \dots \cup T_n$, we define $T_{n+1} = f^{-1}(T_n)$ and for each $a \in T_{n+1}$ we set $b \preceq a$ iff $b \in T_0 \cup \dots \cup T_n$ and $b = f(a)$ or $b \preceq f(a)$ (or if $b = a$). It can be easily checked that \preceq is a tree ordering on $T = \bigcup_{n \in \omega} T_n$ that has the required properties. ■

THEOREM 11. $\Delta_5 \rightarrow \text{Tr} \rightarrow \text{V}$.

Proof. The first implication is clear since $\Delta_5 \leftrightarrow \text{Tr}^2$ (Theorem 10).

To prove $\text{Tr} \rightarrow \text{V}$, suppose that X is V -infinite, so that there exists a bijection $F : 2 \times X \rightarrow X$. The function $f : X \rightarrow X$ given by $f(x) = F(\langle 0, x \rangle)$ is one-to-one; let $Y = f''X$ and $Z = X \setminus Y$. For each $z \in Z$ we have $f(z) \neq z$, so the orbit $\{f^n(z) : n \in \omega\}$ is infinite and can be naturally ordered in order type ω .

The union of all the f -orbits of elements of Z is then naturally ordered as a tree of height ω with no maximal elements (each $z \in Z$ is a root and there is no branching). If there are elements $y \in Y$ that are not in that

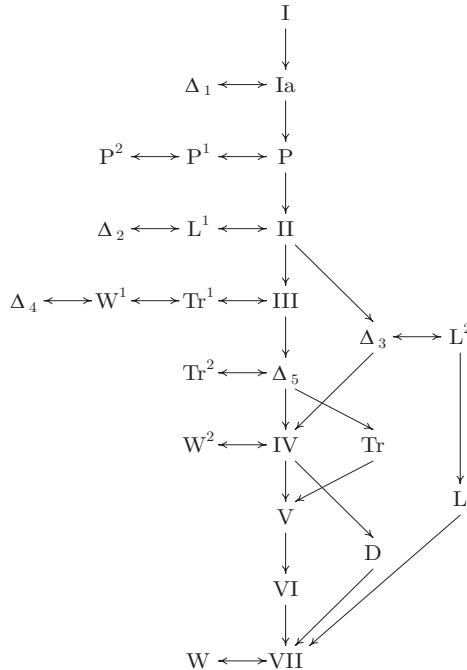

Fig. 1. Relations between definitions of finiteness. Arrows indicate implications (cf. Section 3). Arrows pointing in only one direction are not reversible in ZF (cf. Section 4).

union we place them below the root $F(1, f^{-1}(y))$. This finishes defining the desired tree order on all of X . ■

(Notice that a small variation of the proof above yields the ZF fact that if $|X| = 2 \cdot |X|$ then $|X| = \aleph_0 \cdot |X|$.)

COROLLARY 1. $\text{Tr}^1 \leftrightarrow \text{W}^1 \leftrightarrow \text{III}$.

Proof. See Remark 5; Theorem 11 puts the notion Tr between III and VII. ■

All the implications between notions of finiteness are summarized in Figure 1. Notice that if \mathcal{Q} is any notion of finiteness given in Section 2, then $\text{I} \rightarrow \mathcal{Q} \rightarrow \text{VII}$. Now if the Axiom of Choice is assumed, and every set is well-orderable, then $\text{VII} \rightarrow \text{I}$. Thus all the notions in Figure 1 are legitimate notions of finiteness in the sense of being equivalent to I-finiteness under AC.

4. Independence results. In this section, we show that the implications established above are the only ones that can be proved in ZF.

We begin with references to the known results. Lévy [al58] proved that if \mathcal{Q} and \mathcal{Q}' are any of the notions listed in Definition 1, then $\mathcal{Q} \not\rightarrow \mathcal{Q}'$ whenever \mathcal{Q} is below \mathcal{Q}' in that list. (The techniques to give these independence results in ZF were not available to Lévy in 1958. He worked in the context of the weaker theory ZFA, but his results all transfer to ZF by the Jech–Sochor Embedding Theorem; see comments on this below.) Truss [jt74] showed $\text{III} \not\rightarrow \Delta_3$ and $\Delta_3 \not\rightarrow \Delta_5$, meaning that for \mathcal{Q} in Definition 1, $\mathcal{Q} \rightarrow \Delta_3$ only if \mathcal{Q} is listed above III, and that $\Delta_3 \rightarrow \mathcal{Q}$ only if \mathcal{Q} is IV or listed below IV. It also follows, since $\Delta_3 \rightarrow \text{IV}$, that $\text{IV} \not\rightarrow \Delta_5$. De la Cruz [odlc02] established that $\Delta_5 \not\rightarrow \text{III}$ and that $\text{V} \not\rightarrow D$, while Howard and Yorke [hy89] showed that $D \not\rightarrow \text{VI}$. So $\mathcal{Q} \rightarrow D$ only if \mathcal{Q} is above V in Definition 1, and $D \not\rightarrow \mathcal{Q}$ for any \mathcal{Q} in Definition 1 above VII. This settles all questions about implications between the notions of finiteness from Definitions 1, 2, and 3 of Section 2.

We now begin to address the implications involving notions from Definitions 4 and 5. We can use the known fact that $\text{I} \not\rightarrow \text{Ia}$ to separate P-finiteness from Ia-finiteness. Recall that an *amorphous* set is one that is Ia-finite but infinite (i.e., an infinite set with no partition into two infinite parts).

THEOREM 12. $\text{P} \not\rightarrow \text{Ia}$.

Proof. Working from ZF plus “There exists an amorphous set” (which is equiconsistent with ZF by the remarks above) we prove that there is a set which is P-finite and Ia-infinite. Given an amorphous set X , there must be another amorphous set Y with $X \cap Y = \emptyset$. Clearly $X \cup Y$ is not amorphous; it is Ia-infinite.

Both X and Y are Ia-finite and hence P-finite (Ia \rightarrow P by Theorem 3). Any partial order on $X \cup Y$ must have an element a which is maximal in X and an element b which is maximal in Y . At least one of a or b must be maximal in $X \cup Y$, which shows that $X \cup Y$ is P-finite. ■

For most of the remaining independence results, we will work directly with models of set theory rather than relying on previously obtained independence results as in the proof of Theorem 12. We will obtain our results in the theory ZFA, a weakened version of ZF which allows for the existence of *atoms*, objects with no elements yet different from each other and from the empty set (extensionality must be weakened so that it applies only to sets); we will assume that the class A of atoms is actually a set. Models of ZF are rigid, but in a model M of ZFA the permutations of A correspond exactly to the automorphisms of the universe (that is, \in -automorphisms of M which constitute a definable class in M). When M satisfies ZFA + AC + “ A is infinite” (a theory that is consistent relative to ZF), the rich provision of automorphisms allows us to construct so-called *permutation submodels* of M , which are models of ZFA where AC fails in a controlled way.

Even though ZFA is a weaker theory, the independence results we obtain in this way will also hold in ZF, by virtue of the Jech–Sochor Embedding Theorem [tjj73, Chapter 6; js66], which allows for the embedding of initial segments of permutation models into models of ZF. Without going into the details, we only remark here that if a sentence of the form

$$\exists x (x \text{ is } \mathcal{Q}\text{-finite and } \mathcal{Q}'\text{-infinite})$$

is true, then its truth is realized in an initial segment of the universe.

We give a summary of the construction of permutation models. For a detailed description of permutation models, see [tjj73]; we will make note below where our formulation differs slightly from the one there. Fix a model V of ZFA + AC + “ A is infinite”, where A is the set of atoms of V , and a group $G \in V$ of permutations of A . Abusing the notation, we identify each $\pi \in G$ with the class function $\pi : V \rightarrow V$ defined by the rule $\pi(\emptyset) = \emptyset$ and $\pi(x) = \{\pi(y) : y \in x\}$ for all x . For any $x \in V$, we define the *stabilizer of x in G* to be the group $G_x = \{\pi \in G : \pi x = x\}$; the *pointwise stabilizer of x in G* is the group $\text{fix}_G(x) = \{\pi \in G : \pi \upharpoonright x = \text{Id}\} = \bigcap_{y \in x} G_y$. Now, if x and y are objects (sets or atoms), we say x *supports* y if $\text{fix}_G(x) \subseteq G_y$. We define a *base of supports* (for G) as a set B with the following properties:

- $G_B = G$;
- every $a \in A$ is supported by some $b \in B$;
- for every $b_0, b_1 \in B$, there is a $c \in B$ which supports every element of $b_0 \cup b_1$.

(In [tjj73], a permutation model is defined in terms of a *normal filter* on G instead of a base of supports for G . The formulations are equivalent. The filter associated with the base of supports B is the filter generated by $\{\text{fix}_G(b) : b \in B\}$.) A commonly used base of supports is the set of finite subsets of A , called the *base of finite supports*. Now we say $x \in V$ is *symmetric* (with respect to B and G) if it is supported by some $b \in B$; we say it is *hereditarily symmetric* if every element of the transitive closure of x is symmetric. The class $\mathcal{N}_{G,B}$ of all hereditarily symmetric sets with respect to G and B is a model of ZFA, and we call it the *permutation model* obtained from G and B .

Howard and Yorke [hy89] have presented the permutation model $M6$, whose construction is given below, and proved that in this model, the set A is D -infinite.

THEOREM 13. *In the model $M6$, the set A of atoms is Tr -finite and L -finite.*

Proof. The model $M6$ is constructed by first taking a model of $\text{ZFA} + \text{AC}$ and letting A be ordered in the order type of the rationals. Then $M6$ is the permutation model obtained from the group G of permutations which move finitely many elements of A and the base of supports B of bounded subsets of A .

Let \preceq be a tree ordering on A that is in $M6$; we will find a \preceq -maximal element. Since \preceq is symmetric, there is a support $E \in B$ such that $\text{fix}(E)$ is a subset of G_{\preceq} ; in other words, every $\pi \in \text{fix}(E)$ is a \preceq -automorphism of A . Pick two distinct elements a and b in $A \setminus E$. The permutation $\pi := (a, b)$ which just switches a and b is in $\text{fix}(E)$. It follows that $a \preceq b$ iff $b \preceq a$; these cannot be both true so a and b are incomparable under \preceq . If a is not a maximal element, then there is $c \in A$ such that $a \preceq c$ and $b \not\preceq c$. But then $\pi a \preceq \pi c$, which means $b \preceq c$ and we have a contradiction. So a is a maximal element.

Next, suppose \leq is a linear ordering of A in $M6$ and let $E \in B$ be a support for \leq . Pick two distinct elements a and b in $A \setminus E$. Arguing as above we find that a and b must be incomparable under \leq , which is a contradiction since \leq is a linear order. Hence, there is no linear ordering of A at all in $M6$. ■

COROLLARY 2. $\text{Tr} \not\rightarrow D$, $L \not\rightarrow D$, $\text{Tr} \not\rightarrow \text{IV}$, and $L \not\rightarrow \text{IV}$.

Proof. It was just shown that in the permutation model $M6$, the set A of atoms is Tr -finite and L -finite. That A is D -infinite is in [hy89]. To see that A is IV -infinite in $M6$, take any infinite $E \in B$. Since each $E \in B$ is subset of A and a support for a well-ordering of itself, A has well-ordered infinite subsets in $M6$. ■

Consequently, $\text{Tr} \rightarrow \mathcal{Q}$ only if \mathcal{Q} is V, VI, or VII, or equivalent to one of these.

Any union of an amorphous set with a countably infinite set is another, perhaps simpler example of a set that is Tr- and L-finite but IV-infinite. However, the example of Corollary 2 may be preferable in that it shows Tr- and L-finiteness of a set X to be consistent with the stronger property “Every infinite subset of X is IV-infinite”.

THEOREM 14. $\Delta_3 \not\rightarrow \text{Tr}$.

Proof. Consider Fraenkel’s Second Model, in which A is the union of a disjoint family of countably many pairs, $A = \bigcup\{P_n : n \in \omega\}$, with no choice function.

For every $n \in \omega$, define F_n to be the set of all choice functions on $\{P_k : k \leq n\}$ and set $F = \bigcup\{F_n : n \in \omega\}$. It is shown in Truss [jt74] that F is Δ_3 -finite in this model. However, the \subseteq relation on F is a tree ordering with no maximal element, so F is Tr-infinite. ■

Since $\Delta_3 \rightarrow \text{IV}$, it follows that $\mathcal{Q} \not\rightarrow \text{Tr}$ for any \mathcal{Q} listed below III in Definition 1. We also see that $\Delta_5 \rightarrow \text{Tr}$ but $\Delta_5 \not\rightarrow \Delta_3$, meaning $\text{Tr} \not\rightarrow \Delta_3$.

THEOREM 15. III $\not\rightarrow$ L.

Proof. Truss [jt74] showed that the set A in Mostowski’s ordered model is III-finite. This set is infinite and linearly orderable (see Howard and Rubin [hr98]) and so L-infinite. ■

It follows from the previous theorem, since III \rightarrow IV \rightarrow D and III \rightarrow $\Delta_5 \rightarrow \text{Tr}$, that $\mathcal{Q} \not\rightarrow$ L for any \mathcal{Q} in Definition 1 below II, and also that D $\not\rightarrow$ L and Tr $\not\rightarrow$ L.

The last task of this section is to show that II $\not\rightarrow$ P. For the remainder of this section, the relation symbol \preceq will refer to a universal homogeneous partial order on A , where A is a set of atoms. A partial order is called *universal* if every finite partial order can be embedded in it, and is called *homogeneous* if every order isomorphism between two of its finite subsets can be extended to an automorphism of the entire set. Notice that such a partial order has no maximal element. For a proof of the existence of a countable universal homogeneous partial order, see Jech [tjj73].

Given a finite subset E of A , we say that two elements $a \in A$ and $b \in A$ have the same *E-type* if there is a \preceq -isomorphism from $E \cup \{a\}$ to $E \cup \{b\}$ whose restriction to E is the identity. (Equivalently, b and c have the same *E-type* iff b and c satisfy exactly the same sentences in the structure $\langle A, \preceq, e_1, \dots, e_n \rangle$.)

For a proof of part (1) of the following lemma, which is straightforward, see [tjj73]. Part (1) can be used to prove part (2) (which is not used in full until Theorem 19).

LEMMA 4. Let $\langle A, \preceq \rangle$ be a countable universal homogeneous poset.

- (1) Let $\langle F, \leq \rangle$ be a finite poset. If $E \subset F$ and $f : E \rightarrow A$ is a partial order embedding, then there is an embedding of F into A that extends f .
- (2) Let E be a finite subset of A ; let a and b be \preceq -incomparable elements of A with the same E -type, and let D be a finite subset of A disjoint from $E \cup \{a, b\}$. Then there is an automorphism π of $\langle A, \preceq \rangle$ that fixes E pointwise, switches a and b , and is such that $\pi D \cap D = \emptyset$.

THEOREM 16. II $\not\leftrightarrow$ P.

Proof. Let \mathcal{N} be the permutation model obtained from the group G of all order automorphisms of $\langle A, \preceq \rangle$, where \preceq is a countable universal homogeneous partial order, and from the base B of finite supports. Since \preceq is symmetric with respect to G and has no maximal element, A is P-infinite in \mathcal{N} .

Recall that II \leftrightarrow L¹ (Theorem 5). We will show that A is L¹-finite in \mathcal{N} : every linearly ordered set mapped onto by A is finite. Let $\langle T, \leq \rangle$ be a set with a linear order in \mathcal{N} , and also in \mathcal{N} let $t : A \rightarrow T$ be an onto function. Let $E \in B$ be a support for both t and \leq .

Let a and b be any two elements of A that have the same E -type; we will show that $t(a) = t(b)$. First, suppose a and b are incomparable under \preceq . Then there is a $\pi \in G$ that switches a and b while fixing E pointwise. Suppose without loss of generality that $t(a) \leq t(b)$. Since π preserves both t and \leq , we have $t(\pi a) \leq t(\pi b)$; in other words $t(b) \leq t(a)$. Thus $t(a) = t(b)$. More generally, a and b may not be incomparable. However, by Lemma 4 there is a $c \in A$ such that c has the same E -type as a and b and such that c is comparable with neither a nor b , in which case the argument just presented shows that $t(a) = t(c) = t(b)$. Now, since there are only finitely many E -types, the range T of t must be finite, and this finishes the proof that A is L¹-finite in \mathcal{N} . ■

5. Closure under unions. For a class \mathcal{C} of sets, we say that \mathcal{C} is *closed under unions* if whenever both $X \in \mathcal{C}$ and $X \subset \mathcal{C}$ we have $\bigcup X \in \mathcal{C}$. We will use the terminology “ \mathcal{Q} -finiteness is closed under unions” as shorthand for “The class of \mathcal{Q} -finite sets is provably closed under unions, in ZF”. Since the class of finite sets is closed under unions, closure under unions is a reasonable property for a notion of finiteness to have. We will investigate closure under unions for some of the strongest notions of finiteness defined in Section 1.

The class of II-finite sets is closed under unions. (Recall that II \leftrightarrow L¹. It is easy to check that both (1) L-finiteness is closed under unions and (2) \mathcal{Q}^1 -finiteness is closed under unions whenever \mathcal{Q} -finiteness is.) However, this is the strongest notion of finiteness we have studied which has this property. The class of Ia-finite sets famously lacks closure under unions; a disjoint union of two amorphous sets is obviously not amorphous. A Ia-

finite union of Ia-finite sets must be II-finite, since II-finiteness is closed under unions; we will show that it must in fact be P-finite, giving a stronger closure property (recall that P-finiteness is intermediate in strength between Ia- and II-finiteness). We will also show that P-finiteness itself is not closed under unions, so the best we can currently say about a P-finite union of P-finite sets is that it is II-finite.

We omit the proof of the following simple characterization.

LEMMA 5. *A given set X is a finite union of Ia-finite sets if and only if there is some $n \in \omega$ such that every partition of X has at most n infinite parts.*

Next, we show P-finiteness for a limited class of Ia-finite unions.

LEMMA 6. *Any Ia-finite union of finite sets is also a finite union of Ia-finite sets (and hence is P-finite).*

Proof. Let S be a Ia-finite collection of finite sets. Since S is Ia-finite, all but finitely many of its members must have the same size. Set aside the finitely many oddballs and assume that all members of S have cardinality n . Let $X = \bigcup S$.

Suppose, by way of contradiction, that X has a partition T into $n + 1$ infinite sets. For each $s \in S$, let $f(s)$ be the set of elements of T that have empty intersection with s . Note that $f(s)$ is non-empty for each s , since $|s| < |T|$. Now, since S is Ia-finite, there is a $T' \subset T$ such that $f(s) = T'$ for all but finitely many $s \in S$. But then $t \in T'$ has non-empty intersection with only finitely many $s \in S$, so t is finite, and we have a contradiction.

Thus X has no partition into more than n infinite sets, and the proof is finished by Lemma 5. (Finally, note that a finite union of Ia-finite sets is easily seen to be P-finite, as in the proof of Theorem 12.) ■

Now we will show that every Ia-finite union of Ia-finite sets is P-finite. We remark that the idea of the following proof can be expressed in terms of ultrafilters. Every amorphous set has a natural non-trivial ultrafilter (comprising the cofinite subsets). Although the empty ultrafilter is usually disallowed, take it to be the natural ultrafilter on any finite set. This gives a natural ultrafilter (which may be empty) on any Ia-finite union of Ia-finite sets. Expressed in these terms, the previous lemma says that a set which is small with respect to this ultrafilter must be P-finite; this is exploited in the next proof.

THEOREM 17. *A Ia-finite union of Ia-finite sets is P-finite.*

Proof. Let S be a Ia-finite set of Ia-finite sets, and let $x = \bigcup S$. To show that x is P-finite, it suffices to show, by Theorem 3, that x cannot be partitioned into two P-infinite parts.

Let $\{a, b\}$ be any partition of x into two parts. Since each $t \in S$ is Ia-finite, either $t \cap a$ or $t \cap b$ is finite. Thus the two subsets of S defined here are disjoint:

$$S_a = \{t \in S : t \cap a \text{ is infinite}\}, \quad S_b = \{t \in S : t \cap b \text{ is infinite}\}.$$

Since S is Ia-finite, one of those two sets, say S_a , is finite. Think of a as the union of the two sets $\bigcup\{t \cap a : t \in S_a\}$ and $\bigcup\{t \cap a : t \in S \setminus S_a\}$. The former is a finite union of Ia-finite sets, and the latter is a Ia-finite union of finite sets. By Lemma 6, a is P-finite. ■

As we show next, the converse of Theorem 17 cannot be proved without assuming some choice.

THEOREM 18. *It is consistent in the theory ZF that not every P-finite set is a Ia-finite union of Ia-finite sets.*

Proof. Let \mathcal{N} be the permutation model obtained from the group G of all permutations of an infinite set A of atoms, and the base B of supports given by finite partitions of A .

To see that A is P-finite, let \leq be a partial order of A in \mathcal{N} , supported by a finite partition E of A . Let $n = |E|$. Consider a chain of elements $a_0 \leq \dots \leq a_n$. There must be i and j in n such that a_i and a_j are both in the same member of E . Then the permutation $\pi = (a_i, a_j)$ is in $\text{fix}(E)$, and it follows that $a_i \leq a_j$ iff $a_j \leq a_i$, so in fact $a_i = a_j$. This shows that all \leq -chains have size at most n , and consequently there must be a \leq -maximal element.

Now suppose, working in \mathcal{N} , that T is a Ia-finite set of Ia-finite subsets of A ; we will show that $\bigcup T \neq A$. First observe that since each $E \in B$ is a member of \mathcal{N} , there is no subset of A that is amorphous in \mathcal{N} . Thus the elements of T are in fact finite subsets of A . By Lemma 6, there is a finite set S of Ia-finite sets such that $\bigcup T = \bigcup S$. Again, the Ia-finite members of S must be finite, and so $\bigcup S$ is finite and therefore just a proper subset of A . ■

If it were true that P-finiteness were closed under unions, then Theorem 17 could have been obtained as a trivial consequence. However, the following theorem shows that P-finiteness is not provably closed under unions in ZF. The proof uses forcing to extend a permutation model. Forcing in the context of ZFA is not much different from ZF forcing, once it is understood that atoms are to be names for themselves (like the empty set is a name for itself when forcing in ZF). Details may be found in [bs89].

THEOREM 19. *It is consistent with ZF for a P-finite union of P-finite sets not to be P-finite.*

Proof. Let \mathcal{N} be the finite support permutation model used in Theorem 16 to show $\text{II} \not\rightarrow \text{P}$, in which \preceq is a universal homogeneous partial order on A , and where G is the group of \preceq -automorphisms of A .

By forcing, we will extend \mathcal{N} by adding a new partition T of A so that in the extension $\mathcal{N}[T]$, T is a \mathbf{P} -finite collection of \mathbf{P} -finite subsets of A . Clearly, the partial order \preceq will witness that A itself is not \mathbf{P} -finite in $\mathcal{N}[T]$ (nor in \mathcal{N}), so in $\mathcal{N}[T]$, A is a \mathbf{P} -finite union of \mathbf{P} -finite sets that is not \mathbf{P} -finite.

Let \mathbf{P} be the notion of forcing whose conditions are partitions of finite subsets of A with the qualification that no two elements in the same part of any of these partitions are \preceq -comparable. We say that a condition p extends a condition q if $\bigcup q \subseteq \bigcup p$ and the restriction of the partition p to the set $\bigcup q$ is the partition q .

Let Γ be a \mathbf{P} -generic filter over \mathcal{N} . There is a partition T of A defined by Γ (and from which Γ may be defined); say a and b are in the same part of T if there is a condition $p \in \mathbf{P}$ with $\{a, b\} \in p \in \Gamma$. For each $t \in T$, the elements of t are pairwise \preceq -incomparable. For each $a \in A$, let T_a denote the part such that $a \in T_a \in T$. Let \dot{T} be a standard \mathbf{P} -name for T , and for each $a \in A$ let \dot{T}_a be a standard \mathbf{P} -name for T_a . The theorem is concluded by proving the following two claims.

CLAIM A. For each $a \in A$, the set T_a is \mathbf{P} -finite in $\mathcal{N}[T]$.

CLAIM B. T is \mathbf{P} -finite in $\mathcal{N}[T]$.

Proof of Claim A. Fix $a \in A$, and let \leq be a partial order on T_a . Suppose $\dot{\leq}$ is a \mathbf{P} -name for \leq , and let E be a finite support for $\dot{\leq}$ in \mathcal{N} . Let n be the number of E -types (with respect to the universal homogeneous order \leq on A). We will show that there is a \leq -maximal element in T_a by showing that any chain in T_a linearly ordered by \leq has cardinality at most n .

So by way of contradiction, suppose there is a chain of elements in T_a with more than n elements. Since there are only n E -types, there must be distinct elements b and c in this chain with the same E -type, say with $b \dot{\leq} c$. Let $p \in \mathbf{P}$ be such that $p \Vdash b \dot{\leq} c$. Assume also that $p \Vdash \{b, c\} \subset \dot{T}_a$, which is to say that $\{a, b, c\}$ is a subset of some element of p . Since b and c are \preceq -incomparable (because they are both in T_a) and have the same E -type, there is an automorphism $\pi \in G$ such that π fixes E pointwise and π switches b and c . Furthermore, we can arrange that $\bigcup(\pi p) \cap \bigcup p \subseteq E \cup \{b, c\}$ (Lemma 4(2) with $D = \bigcup p \setminus (E \cup \{b, c\})$). From this last remark and the fact that b and c are in the same part of p , it follows that p and πp are compatible. And yet $\pi p \Vdash \pi b \dot{\leq} \pi c$, which is to say $\pi p \Vdash c \dot{\leq} b$. This contradiction finishes the proof of the first claim.

Proof of Claim B. Let \leq be a partial order on T in $\mathcal{N}[T]$, and let $\dot{\leq}$ be a \mathbf{P} -name for \leq supported by E in \mathcal{N} . Let T_1 and T_2 be distinct elements of T , neither of which meets E ; we will show that T_1 and T_2 cannot be comparable under \leq . By \mathbf{P} -genericity of T , there is some $b \in T_1$ and some $c \in T_2$ such that b and c are \preceq -incomparable and of the same E -type.

Now suppose by way of contradiction that there is a condition $p \in \Gamma$ such that $p \Vdash \dot{T}_b \leq \dot{T}_c \wedge \dot{T}_b \neq \dot{T}_c$. Since neither T_a nor T_b meets E in $\mathcal{N}[T]$, we see that neither b nor c is in the same part of p as any element of E . Again, we can find $\pi \in G$ such that π fixes E pointwise, π switches b and c , and is such that $\bigcup(\pi p) \cap \bigcup p \subseteq E \cup \{b, c\}$. Again, πp and p must be compatible, yet $\pi p \Vdash \dot{T}_c \leq \dot{T}_b$, and we have a contradiction. Thus elements of T that do not meet E are \leq -incomparable. Since only finitely many elements of T do meet E , there must be a \leq -maximal element in T . ■

References

- [bs89] A. Blass and A. Scedrov, *Freyd's models for the independence of the axiom of choice*, Mem. Amer. Math. Soc. 79 (1989), no. 404.
- [rd72] R. Dedekind, *Stetigkeit und irrationale Zahlen*, Vieweg, Braunschweig, 1872.
- [odlc02] O. De la Cruz, *Finiteness and choice*, Fund. Math. 173 (2002), 57–76.
- [hr98] P. E. Howard and J. E. Rubin, *Consequences of the Axiom of Choice*, Amer. Math. Soc., Providence, RI, 1998.
- [hy89] P. E. Howard and M. F. Yorke, *Definitions of finite*, Fund. Math. 133 (1989), 169–177.
- [tjj73] T. J. Jech, *The Axiom of Choice*, Stud. Logic Found. Math. 75, North-Holland, Amsterdam, 1973.
- [js66] T. J. Jech and A. Sochor, *Applications of the Θ -model*, Bull. Acad. Polon. Sci. Sér. Sci. Math. Astronom. Phys. 14 (1966), 351–355.
- [al58] A. Lévy, *The independence of various definitions of finiteness*, Fund. Math. 46 (1958), 1–13.
- [am38] A. Mostowski, *Über den Begriff einer endlichen Menge*, C. R. Séances Soc. Sci. Lett. Varsovie Cl. III 31 (1938), 13–20.
- [at24] A. Tarski, *Sur les ensembles finis*, Fund. Math. 6 (1924), 45–95.
- [jt74] J. Truss, *Classes of Dedekind finite cardinals*, *ibid.* 84 (1974), 187–208.

Omar De la Cruz
 Department of Mathematics
 Purdue University
 West Lafayette, IN, U.S.A.
 and
 Centre de Recerca Matemàtica
 Barcelona, Spain
Current address:
 Department of Statistics
 University of Chicago
 5734 S. University Avenue
 Chicago, Illinois 60637-1514, U.S.A.
 E-mail: odlc@uchicago.edu

Damir D. Dzhamalov
 Department of Mathematics
 Purdue University
 West Lafayette, IN, U.S.A.
Current address:
 Department of Mathematics
 University of Chicago
 5734 S. University Avenue
 Chicago, Illinois 60637-1514, U.S.A.
 E-mail: damir@math.uchicago.edu

Eric J. Hall
 Department of Mathematics and Statistics
 University of Missouri–Kansas City
 5100 Rockhill Rd.
 Kansas City, MO 64110-2499, U.S.A.
 E-mail: halle@umkc.edu

*Received 29 December 2004;
 in revised form 24 October 2005*